

CHAPTER 2: Two degree-of-freedom Vibration

The spring/mass system considered in Chapter 1 was constrained to move in a single axial direction. It followed that the system had one **degree-of-freedom** as it is possible to uniquely define the position of the system by one coordinate, viz, x . Most vibratory systems have many degrees of freedom and therefore more complex models are required to model their vibration behaviour. It is useful to consider a two degree-of-freedom system as this will furnish information which may helpfully be extrapolated to systems with many degrees of freedom. We will consider systems without damping initially because:-

1. The maths is easier.
2. In practice the damping is often small.
3. The main results are not too dependent on damping.
4. Damping may be considered later, either quantitatively or qualitatively.

The approach to be adopted initially will not be rigorous mathematically but gives natural frequencies very simply and a more rigorous method will be adopted subsequently.

2.1 Natural frequency calculation

2.1.1 One degree-of-freedom

The approach will be first applied to the single **degree-of-freedom** system already considered and shown in figure 2.1. Since there is no damping the system will vibrate, if disturbed, at its natural frequency and this vibration will be non decaying. The motion may therefore be assumed to be of the form $x(t) = X\sin\omega t$. The equation of motion with no external excitation is,

$$mx''(t) + kx(t) = 0$$

substituting the assumed form of $x(t)$ gives

$$-m\omega^2 X \sin\omega t + kX \sin\omega t = 0$$

as $\sin\omega t$ is not zero for all t

$$X(k - m\omega^2) = 0$$

Now either $X = 0$ and then there is no motion, ie. the system is at rest, or X exists and there is a non-decaying vibration $X\sin\omega t$ if

$$(k - m\omega^2) = 0$$

ie. when

$$\omega = \omega_n = \sqrt{\frac{k}{m}} \text{ the undamped natural frequency.}$$

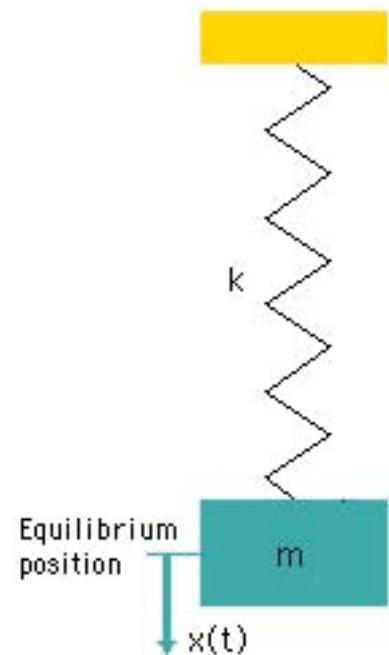

Figure 2.1

Thus we have found the natural frequency by assuming sinusoidal motion under free (ie. not forced) vibration conditions and then finding, in this case, the single frequency at which this is possible. This by definition is the natural frequency.

2.1.2 Two degree-of-freedom

The same approach may be applied to a two degree of freedom system once the equations of motion are known. Consider the two degree-of-freedom system shown in figure 2.2. The two coordinates x_1 and x_2 uniquely define the position of the system, if it is constrained to move axially.

Consider the deflected position at some time t . The free body diagram of the mass m_1 is thus,

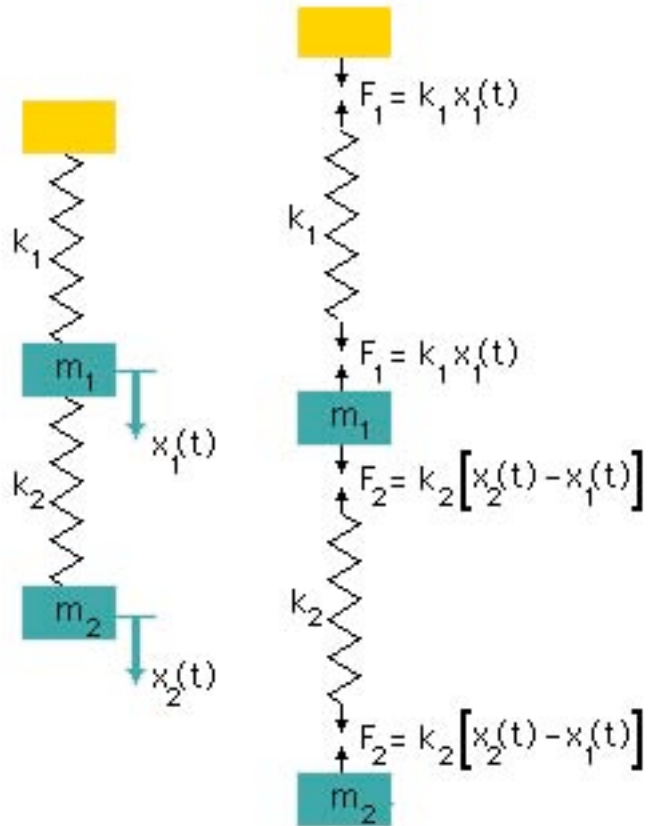
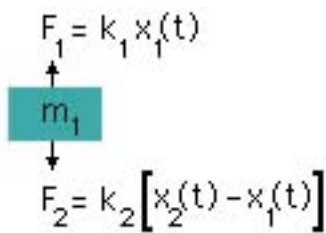
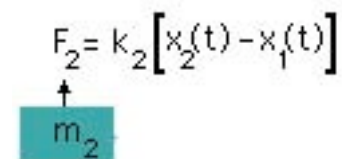

Figure 2.2 Axial two degree-of-freedom system

If we now apply Newton's second law we obtain the equation of motion of the mass m_1 as,

$$m_1 x_1'' = -k_1 x_1 + k_2(x_2 - x_1) \dots\dots\dots (2.1)$$

and the free body diagram of the mass m_2 is as shown and the equation of motion of the mass m_2 is,



$$m_2 x_2'' = -k_2(x_2 - x_1) \dots\dots\dots (2.2)$$

We will now assume sinusoidal motion such that

$$x_1 = X_1 \sin \omega t \quad \text{and} \quad x_2 = X_2 \sin \omega t$$

therefore

$$-m_1 \omega^2 X_1 \sin \omega t = -k_1 X_1 \sin \omega t - k_2 X_1 \sin \omega t + k_2 X_2 \sin \omega t$$

$$\text{and} \quad -m_2 \omega^2 X_2 \sin \omega t = k_2 X_1 \sin \omega t - k_2 X_2 \sin \omega t$$

the $\sin \omega t$ terms cancel and rearranging gives

$$(k_1 + k_2 - m_1\omega^2)X_1 - k_2X_2 = 0 \quad \dots\dots\dots (2.3)$$

$$-k_2X_1 + (k_2 - m_2\omega^2)X_2 = 0 \quad \dots\dots\dots (2.4)$$

from (2.3) $X_2 = \frac{(k_1 + k_2 - m_1\omega^2)}{k_2}X_1 \quad \dots\dots\dots (2.5)$

substituting in (2.4)

$$-k_2X_1 + (k_2 - m_2\omega^2) \frac{(k_1 + k_2 - m_1\omega^2)}{k_2}X_1 = 0$$

ie. $X_1 \left(\frac{m_1m_2\omega^4 - (m_2k_1 + m_2k_2 + m_1k_2)\omega^2 + k_1k_2}{k_2} \right) = 0$

It follows that either $X_1 = 0$, and no motion exists, or motion of the assumed form may occur if,

$$m_1m_2\omega^4 - (m_2k_1 + m_2k_2 + m_1k_2)\omega^2 + k_1k_2 = 0 \quad \dots\dots\dots (2.6)$$

This is a quadratic equation in ω^2 and thus gives two frequencies at which sinusoidal and non-decaying motion may occur without being forced. That is, there are two natural frequencies ω_{n1} and ω_{n2} . As a particular example take the situation where $m_1=m_2=m$ and $k_1=k_2=k$. Then equation (6) becomes,

$$m^2\omega^4 - 3mk\omega^2 + k^2 = 0 \quad \dots\dots\dots (2.7)$$

Solving this equation gives the two natural frequencies as,

$$\omega_{n1} = 0.618\sqrt{\frac{k}{m}} \quad \text{and} \quad \omega_{n2} = 1.618\sqrt{\frac{k}{m}}$$

[It must be noted that the recurrence of the particular digits "618" in this example is not to be taken as indicating that this will normally be the case, rather it is the result of the particular problem being investigated.]

For each frequency there is an associated ratio of X_1/X_2 . Rearranging equation (5) with $m_1=m_2=m$ and $k_1=k_2=k$,

$$\frac{X_1}{X_2} = \frac{k}{(2k - m\omega^2)}$$

for $\omega_{n1} = 0.618\sqrt{\frac{k}{m}}$

$$\frac{X_1}{X_2} = \frac{k}{(2k - 0.382k)} = 0.618$$

and for $\omega_{n2} = 1.618\sqrt{\frac{k}{m}}$

$$\frac{X_1}{X_2} = \frac{k}{(2k - 2.618k)} = -1.618$$

These ratios are called mode shapes, or eigen vectors. [Again it must be noted that the recurrence of the particular digits "618" in this example is not to be taken as indicating that this will normally be the case.]

Mode plots are shown in figure 2.3. In this figure the axial motion amplitude at each position is shown perpendicular to the axis of vibration for clarity of visualisation. It is informative to observe the motion and the animation button will allow this.

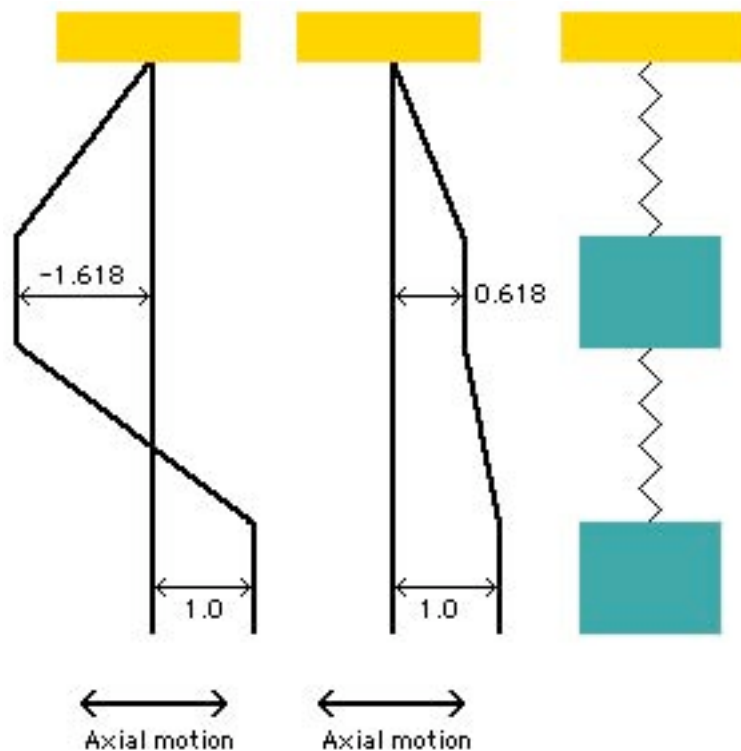

Figure 2.3 Mode shapes - deflection shown perpendicular to the real direction.



It is much more informative to observe an animation of the modes.

Thus there are two modes of vibration with natural frequencies ω_{n1} and ω_{n2} and having associated mode shapes. It should also be noted that the natural frequencies are not dependent on the amplitude of vibration though the ratio of amplitudes (the mode shape) is fixed for a particular natural frequency.

2.1.3 Second example to indicate zero frequency mode

Consider the free/free system shown in figure 2.4. It is called free/free as neither end is attached to earth. This has three degrees of freedom x_1, x_2 and x_3 .

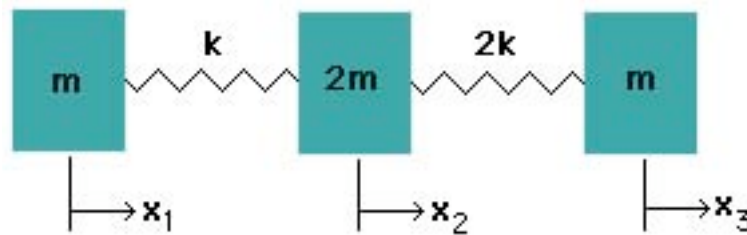

Figure 2.4 Free/free axial three degree-of-freedom system

The equations of motion are

$$mx_1'' = -k(x_1 - x_2) \dots\dots\dots (2.8)$$

$$2mx_2'' = k(x_1 - x_2) - 2k(x_2 - x_3) \dots\dots\dots (2.9)$$

$$mx_3'' = 2k(x_2 - x_3) \dots\dots\dots (2.10)$$

We will now assume sinusoidal motion such that $x_1=X_1\sin\omega t$, $x_2=X_2\sin\omega t$ and $x_3=X_3\sin\omega t$.

Therefore

$$X_1(k - m\omega^2) = kX_2 \dots\dots\dots (2.11)$$

$$-kX_1 + X_2(3k - 2m\omega^2) - 2kX_3 = 0 \dots\dots\dots (2.12)$$

$$X_3(2k - m\omega^2) = 2kX_2 \dots\dots\dots (2.13)$$

from (2.11) and (2.13) substitute

$$X_1 = \frac{k}{(k - m\omega^2)} X_2$$

$$\text{and } X_3 = \frac{2k}{(2k - m\omega^2)} X_2 \quad \text{in (2.12)}$$

thus

$$-k \frac{k}{(k - m\omega^2)} X_2 + X_2(3k - 2m\omega^2) - 2k \frac{2k}{(2k - m\omega^2)} X_2 = 0$$

and thus

$$X_2 \left(\frac{-2m^3\omega^6 + 9m^2\omega^4 - 8m\omega^6}{(k - m\omega^2)(2k - m\omega^2)} \right) = 0$$

It follows that either $X_2=0$, and no motion exists, or motion of the assumed form may occur if,

$$-2m^3\omega^6 + 9m^2\omega^4 - 8m\omega^6 = 0 \dots\dots\dots (2.14)$$

This is a cubic equation in ω^2 and thus gives three frequencies at which sinusoidal and non-decaying motion may occur without being forced. That is, there are three natural frequencies ω_{n1}, ω_{n2} and ω_{n3} .

Solving (2.14) gives $\omega_{n1} = 0$; $\omega_{n2} = 1.1\sqrt{\frac{k}{m}}$ and $\omega_{n3} = 1.81\sqrt{\frac{k}{m}}$

For each of these frequencies there is an associated mode shape given by,

$$\begin{aligned} \text{from (2.11)} \quad \frac{X_1}{X_2} &= \frac{k}{(k - m\omega^2)} \\ \text{from (2.13)} \quad \frac{X_3}{X_2} &= \frac{2k}{(2k - m\omega^2)} \end{aligned}$$

for $\omega = \omega_{n1} = 0$

$$\begin{aligned} X_1/X_2 &= 1.0 \\ X_3/X_2 &= 1.0 \quad \text{ie. } X_1/X_2/X_3 = 1 / 1 / 1 \end{aligned}$$

and for $\omega = \omega_{n2} = 1.1\sqrt{\frac{k}{m}}$

$$\begin{aligned} X_1/X_2 &= -4.55 \\ X_3/X_2 &= 2.27 \quad \text{ie. } X_1/X_2/X_3 = -4.55 / 1 / 2.27 \end{aligned}$$

and for $\omega = \omega_{n3} = 1.81\sqrt{\frac{k}{m}}$

$$\begin{aligned} X_1/X_2 &= -0.44 \\ X_3/X_2 &= -1.56 \quad \text{ie. } X_1/X_2/X_3 = -0.44 / 1 / -1.56 \end{aligned}$$

These mode shapes are shown in figure 2.5. Some authors do not regard the $\omega_{n1} = 0$ result as a mode of vibration, however it will be seen that in many respects its behaviour is similar to any other mode of vibration, ie it is still moving without excitation after infinite time.

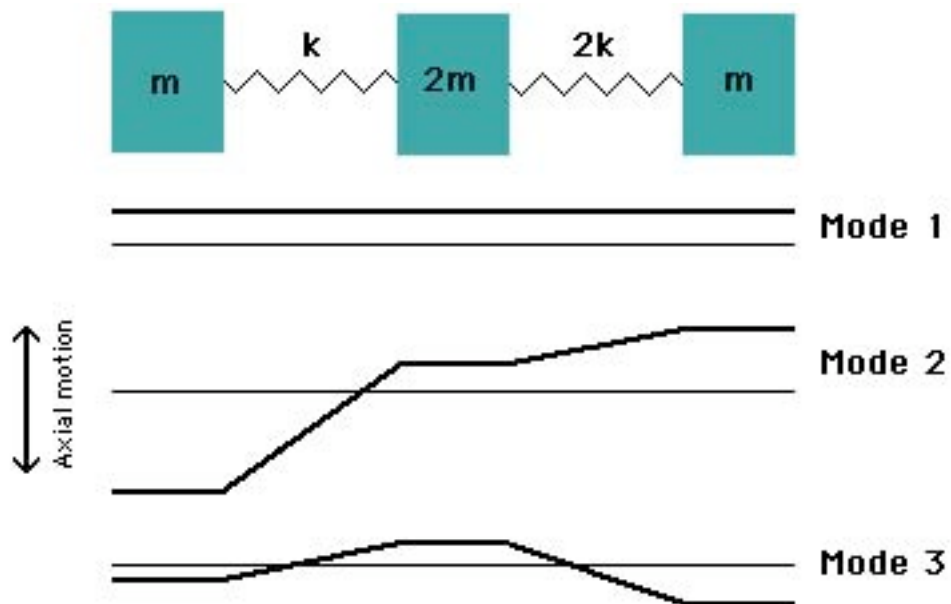

Figure 2.5 Mode shapes - deflection shown perpendicular to the real direction.

2.2 Laplace Transform solution of free vibration

Consider again the axial system (figure 2.2) with the particular values considered previously $m_1=m_2=m$ and $k_1=k_2=k$. The equations of motion were found to be,

$$m_1x_1'' = -k_1x_1 - k_2(x_1 - x_2) \dots\dots\dots (2.1)$$

$$m_2x_2'' = k_2(x_1 - x_2) \dots\dots\dots (2.2)$$

which thus become,

$$mx_1'' + 2kx_1 - kx_2 = 0$$

$$mx_2'' + kx_2 - kx_1 = 0$$

Taking Laplace Transforms

$$m[-x_1'(0) - sx_1(0) + s^2X_1(s)] + 2kX_1(s) - kX_2(s) = 0$$

$$m[-x_2'(0) - sx_2(0) + s^2X_2(s)] + kX_2(s) - kX_1(s) = 0$$

If as an example the initial equations are taken to be

$$x_2'(0) = x_2(0) = x_1'(0) = 0 \text{ and } x_1(0) = X_0$$

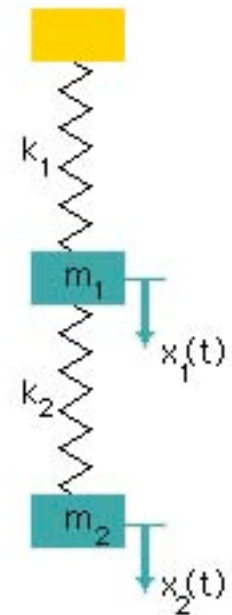

Figure 2.2

$$\text{then } X_1(s)(ms^2 + 2k) + X_2(s)(-k) = msX_0 \dots\dots\dots (2.15)$$

$$X_1(s)(-k) + X_2(s)(ms^2 + k) = 0 \dots\dots\dots (2.16)$$

from (2.16)

$$X_2(s) = \frac{k}{ms^2 + k} X_1(s)$$

substituting in (2.15)

$$X_1(s)(ms^2 + 2k) - \frac{k^2}{ms^2 + k} X_1(s) = msX_0$$

$$X_1(s) = \frac{(ms^2 + k)ms}{(ms^2 + 2k)(ms^2 + k) - k^2} X_0$$

$$X_1(s) = \frac{m^2s^3 + kms}{m^2s^4 + 3kms^2 + k^2} X_0$$

after a great deal of maths this becomes,

$$X_1(s) = \frac{0.276X_0s}{s^2 + \left(0.618\sqrt{\frac{k}{m}}\right)^2} + \frac{0.724X_0s}{s^2 + \left(1.618\sqrt{\frac{k}{m}}\right)^2}$$

Taking inverse Laplace Transforms,

$$x_1 = 0.276X_0 \cos\left(0.618\sqrt{\frac{k}{m}}t\right) + 0.724X_0 \cos\left(1.618\sqrt{\frac{k}{m}}t\right)$$

It has been shown previously that $\omega_{n1} = 0.618\sqrt{\frac{k}{m}}$ and $\omega_{n2} = 1.618\sqrt{\frac{k}{m}}$ the two natural frequencies of the system, so that

$$x_1 = 0.276X_0 \cos(\omega_{n1}t) + 0.724X_0 \cos(\omega_{n2}t)$$

The motion is thus the superposition of vibration at the two natural frequencies. If a similar analysis is done to derive x_2 then the following equation is obtained,

$$x_2 = 0.447X_0 \cos(\omega_{n1}t) - 0.447X_0 \cos(\omega_{n2}t)$$

Again the motion is the superposition of vibration at the two natural frequencies. In addition the ratio x_1/x_2 of the components at the frequency ω_{n1} is $0.276/0.447=0.618$, the first mode shape and at the frequency ω_{n2} the ratio x_1/x_2 is $0.724/(-0.447)=-1.618$, the second mode shape. Thus both natural frequencies are superposed and each is vibrating in its mode shape. The variation of both x_1 and x_2 with $\omega_n t$ ($\omega_n=\sqrt{k/m}$) is shown in figure 2.6.

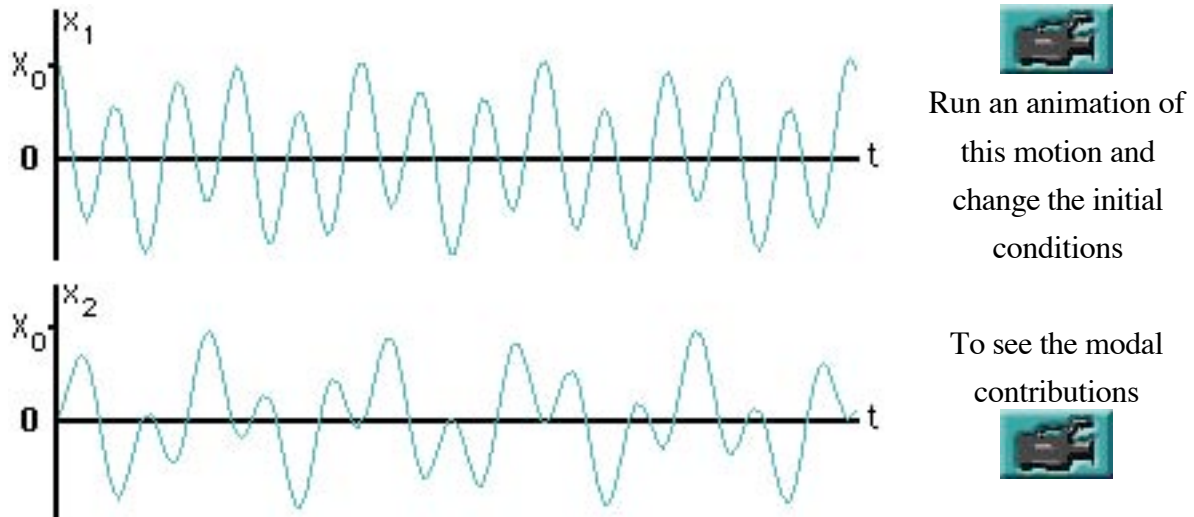

Figure 2.6 Transient motion of two degree-of-freedom system

This superposition of modes may be generalised and we may conclude that the free vibration of undamped systems will normally involve the superposition of all the natural frequencies vibrating in their mode shapes. The particular motion will depend on the initial conditions.

2.3 Laplace transform solution of forced vibration

Consider again the axial system with the particular values considered previously ($m_1=m_2=m$ and $k_1=k_2=k$) and with a sinusoidal input on the abutment given by $x_0 = X_0 \sin \omega t$, as shown in figure 2.7. The equations of motion are,

$$m x_1'' = k(x_0 - x_1) + k(x_2 - x_1)$$

$$m x_2'' = -k(x_2 - x_1)$$

rearranging and substituting for x_0

$$m x_1'' + 2kx_1 - kx_2 = kX_0 \sin \omega t$$

$$m x_2'' + kx_2 - kx_1 = 0$$

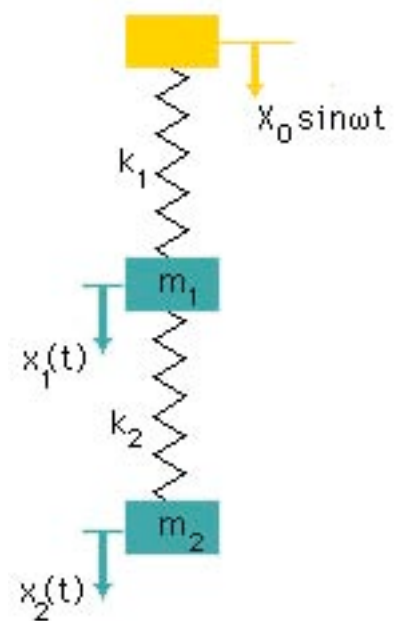

Figure 2.7

If we take Laplace transforms with all the initial conditions zero (otherwise a solution of the form derived in the previous section will be superposed as result of the initial conditions exciting the natural frequencies).

$$m[s^2 X_1(s)] + 2kX_1(s) - kX_2(s) = kX_0 \frac{\omega}{s^2 + \omega^2} \dots\dots\dots (2.17)$$

$$m[s^2 X_2(s)] + kX_2(s) - kX_1(s) = 0 \dots\dots\dots (2.18)$$

from (2.18) $X_2(s) = \frac{kX_1(s)}{ms^2 + k}$

and substituting in (2.17)

$$m[s^2 X_1(s)] + 2kX_1(s) - \frac{k^2}{ms^2 + k} X_1(s) = kX_0 \frac{\omega}{s^2 + \omega^2}$$

therefore

$$X_1(s) = \frac{(ms^2 + k)kX_0\omega}{(s^2 + \omega^2)(m^2s^4 + 3kms^2 + k^2)}$$

taking partial fractions

$$X_1(s) = \frac{As + B}{(s^2 + \omega^2)} + \frac{Cs^3 + Ds^2 + Es + F}{(m^2s^4 + 3kms^2 + k^2)}$$

The second term produces vibration at the two natural frequencies $\omega_{n1} = 0.618\sqrt{\frac{k}{m}}$ and $\omega_{n2} = 1.618\sqrt{\frac{k}{m}}$. This is caused by the start up of the abutment motion. The steady state solution comes from the first term and if the values of A and B are determined then

$$A = 0 \text{ and } B = \frac{\omega(k - m\omega^2)kX_0}{(m^2\omega^4 + 3km\omega^2 + k^2)}$$

and the steady state solution is obtained from

$$X_1(s) = \frac{\omega(k - m\omega^2)kX_0}{(s^2 + \omega^2)(m^2\omega^4 + 3km\omega^2 + k^2)}$$

Taking inverse Laplace Transforms

$$x_1 = \frac{(k - m\omega^2)kX_0 \sin \omega t}{(m^2\omega^4 + 3km\omega^2 + k^2)}$$

If we make $x_1 = X_1 \sin \omega t$ after a great deal of maths it may be shown that

$$\frac{X_1}{X_0} = \frac{0.724}{\left(1 - \frac{\omega^2}{\omega_{n1}^2}\right)} + \frac{0.276}{\left(1 - \frac{\omega^2}{\omega_{n2}^2}\right)} \dots\dots\dots (2.19)$$

Now it has already been shown that the response of a single degree-of-freedom system to abutment excitation is,

$$\frac{X}{X_0} = \frac{\left(1 + 4\xi^2 \frac{\omega^2}{\omega_n^2}\right)^{1/2}}{\left(\left(1 - \frac{\omega^2}{\omega_n^2}\right)^2 + 4\xi^2 \frac{\omega^2}{\omega_n^2}\right)^{1/2}}$$

If the system is undamped ($\xi=0$) this becomes,

$$\frac{X}{X_0} = \frac{1}{\left(1 - \frac{\omega^2}{\omega_n^2}\right)}$$

Thus equation (2.19) represents the superposition of the response of two single degree of freedom systems having natural frequencies ω_{n1} and ω_{n2} respectively. The response of the components and the superposition is shown in figure 2.8 plotted against ω/ω_n ($\omega_{n1}=\sqrt{k/m}$).

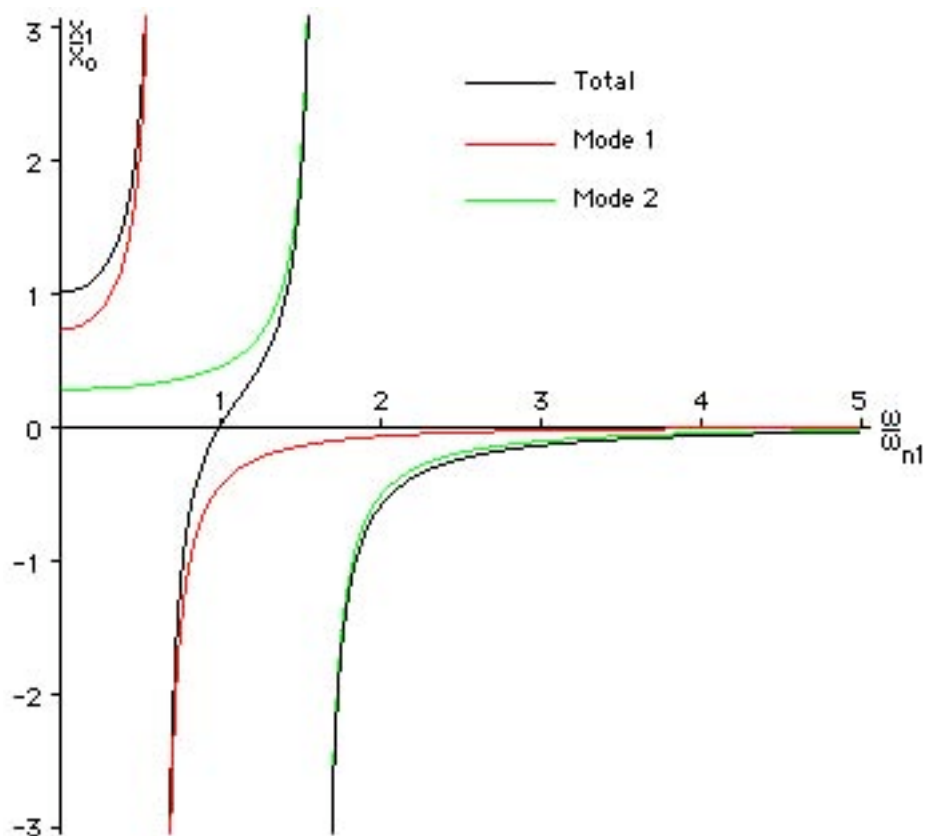

Figure 2.8 Steady state response with modal components.



Now if the response of the mass m_2 had been found the following result would have been obtained as the steady state response,

$$\frac{X_2}{X_0} = \frac{1.17}{\left(1 - \frac{\omega^2}{\omega_{n1}^2}\right)} - \frac{0.17}{\left(1 - \frac{\omega^2}{\omega_{n2}^2}\right)} \dots\dots\dots (2.20)$$

Again the motion is the superposition of the response of two single degree of freedom systems. Thus the response of the system is the superposition of two modes of vibration with their associated mode shapes where each mode responds as a single degree of freedom system. The individual responses and the superposition is shown in Figure 2.9.

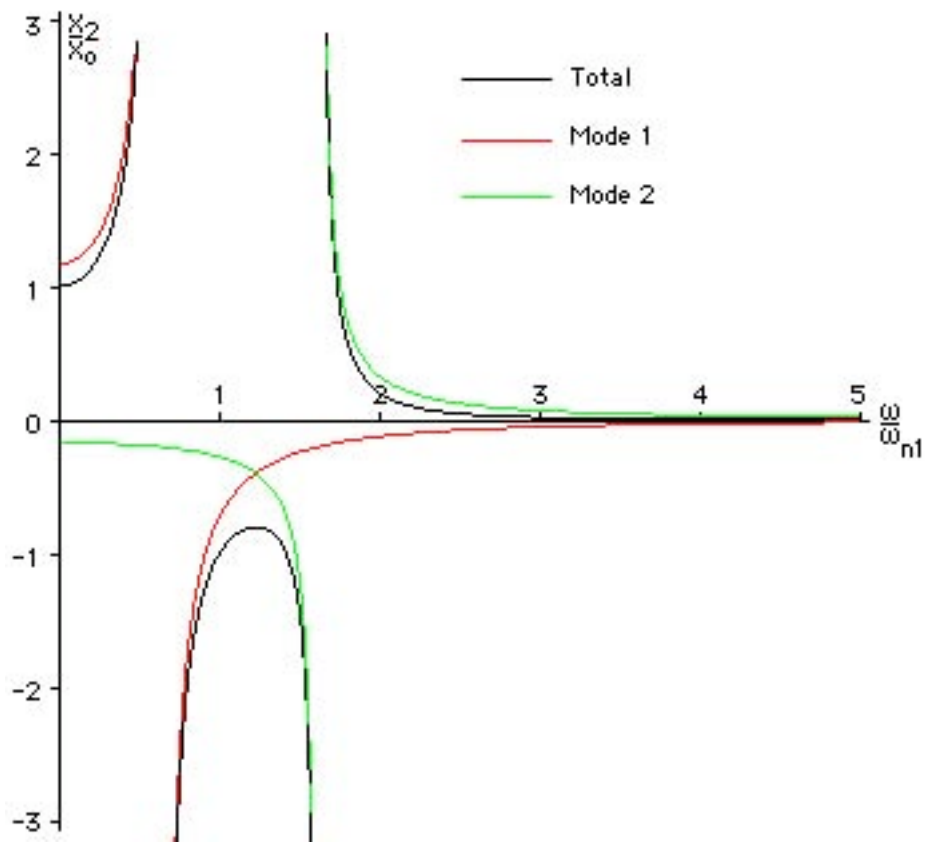

Figure 2.9 Steady state response with modal components.

In addition the ratio of the terms with ω_{n1} in them from equations (2.19) and (2.20) gives X_1/X_2 as $0.724/1.17$ ie. 0.618 , the first mode shape and the ratio of the terms with the frequency ω_{n2} in them gives X_1/X_2 as $0.276/-0.17$ ie. -1.618 , the second mode shape.



2.4 Direct derivation of Steady State Response

Consider the previous example again, but let the excitation be $x_0=X_0e^{i\omega t}$. The equations of motion are,

$$\begin{aligned} mx_1'' + 2kx_1 - kx_2 &= kX_0e^{i\omega t} \\ mx_2'' + kx_2 - kx_1 &= 0 \end{aligned}$$

In the steady state $x_1=X_1e^{i\omega t}$ and $x_2=X_2e^{i\omega t}$ so that,

$$\begin{aligned} -m\omega^2 X_1 e^{i\omega t} + 2kX_1 e^{i\omega t} - kX_2 e^{i\omega t} &= kX_0 e^{i\omega t} \\ -m\omega^2 X_2 e^{i\omega t} + kX_2 e^{i\omega t} - kX_1 e^{i\omega t} &= 0 \end{aligned}$$

and hence

$$(2k - m\omega^2)X_1 - kX_2 = kX_0 \quad \dots\dots\dots (2.21)$$

$$-kX_1 + (k - m\omega^2)X_2 = 0 \quad \dots\dots\dots (2.22)$$

from (2.22)

$$X_2 = \frac{kX_1}{k - m\omega^2}$$

substituting in (2.21)

$$(2k - m\omega^2)X_1 - \frac{k^2 X_1}{k - m\omega^2} = kX_0$$

and therefore

$$\frac{X_1}{X_0} = \frac{(k - m\omega^2)k}{m^2\omega^4 + 3km\omega^2 + k^2} \quad \dots\dots\dots (2.23)$$

which is the same result as obtained previously. However, the maths has been greatly reduced compared to using Laplace Transforms.

2.5 The effects of damping.

The equations of motion without any excitation are,

$$mx_1'' = -k_1x_1 + k_2(x_2 - x_1) - c_1x_1' + c_2(x_2' - x_1')$$

$$mx_2'' = -k_2(x_2 - x_1) - c_2(x_2' - x_1')$$

These equations are difficult to solve without a computer. An animation program allows the motion to be observed for a range of initial conditions and system parameters. Except for particular values of the damping coefficients it is not possible to separate the motion into modes that may be superimposed.

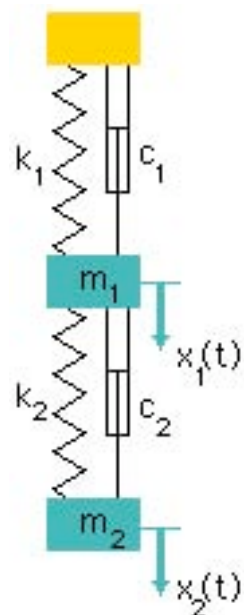

A typical transient is shown in figure 2.10.

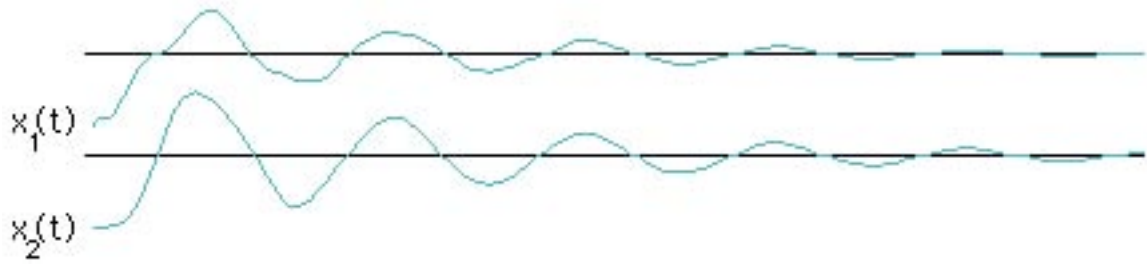

Figure 2.10 Damped transient response

2.5.1 Abutment excitation

When a sinusoidal abutment excitation is applied (see figure 2.11) the equations of motion become,

$$mx_1'' = -k_1(x_1 - x_0) + k_2(x_2 - x_1) - c_1(x_1' - x_0') + c_2(x_2' - x_1')$$

and

$$mx_2'' = -k_2(x_2 - x_1) - c_2(x_2' - x_1')$$

$$\text{where } x_0 = X_0 \sin \omega t$$

The maths is complex but it is found that there is an initial transient before steady state motion is achieved. An example is shown in figure 2.12.

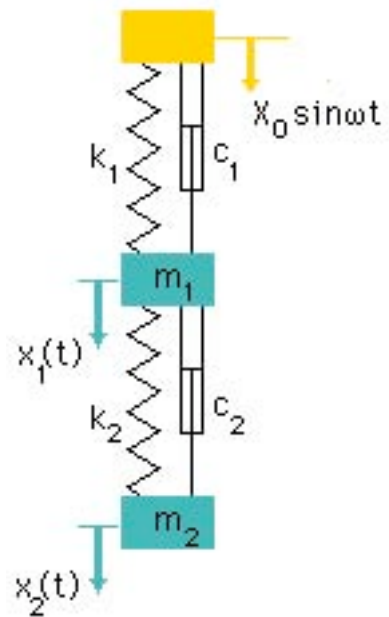

Figure 2.11

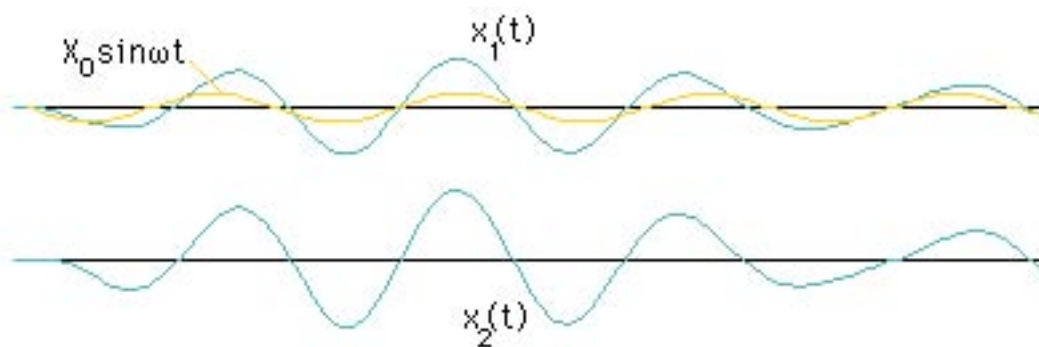

Figure 2.12 Start up transients with sinusoidal excitation



The steady state solution to forced vibration is somewhat easier to obtain as using an excitation and solution involving $e^{i\omega t}$ will give terms of the form $ic\omega e^{i\omega t}$ for each of the viscous damping terms. As there is normally a spring and viscous damper in parallel these will produce terms of the form $(k+i c\omega)e^{i\omega t}$. Thus compared to the undamped case it is only necessary to replace k with $(k+i c\omega)$ in the final solution. Consider the system of Figure 2.7 with the particular values

considered previously $m_1=m_2=m$ and $k_1=k_2=k$ and also with viscous dampers c in parallel with each of the springs. If abutment excitation $X_0 e^{i\omega t}$ is again considered the steady state solution is obtained from equation (2.23) by substituting $k = (k+i\omega c)$. Thus,

$$\frac{X_1}{X_0} = \frac{(k + i\omega c - m\omega^2)k}{m^2\omega^4 + 3(k + i\omega c)m\omega^2 + (k + i\omega c)^2} \dots\dots\dots (2.24)$$

This represents a complex response. If the magnitude alone is examined it will be found to have two resonant peaks and for small values of c these would be found to occur very close to the two undamped natural frequencies $\omega_{n1}=0.618\sqrt{k/m}$ and $\omega_{n2}=1.618\sqrt{k/m}$. Figure 2.13 shows such a response for some particular numerical examples.

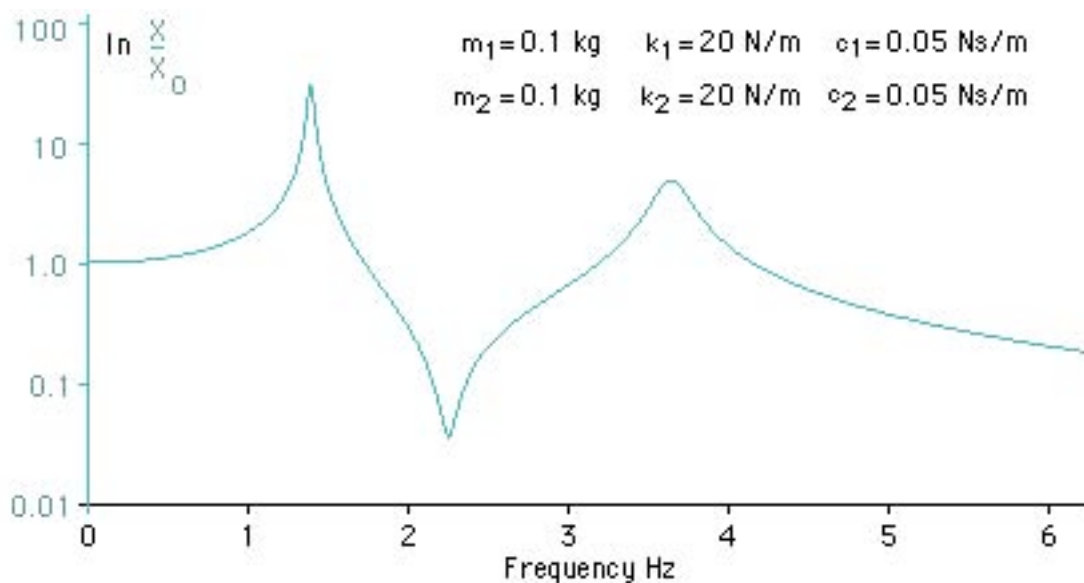

Figure 2.13 Response of damped two degree-of-freedom system



2.5.2 External force

If the excitation is a sinusoidally varying force similar results are obtained. Consider such a force applied to the mass 1 as shown. The equations of motion are,

$$m x_1'' = -k_1 x_1 + k_2(x_2 - x_1) - c_1 x_1' + c_2(x_2' - x_1') + F \sin \omega t$$

and

$$m x_2'' = -k_2(x_2 - x_1) - c_2(x_2' - x_1')$$

There are start up transients

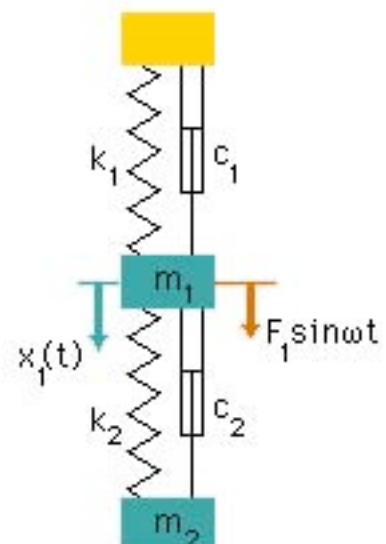

and the steady state solution can be shown to be found by using $Fe^{i\omega t}$ and a response for the mass 1 as $X_1e^{i\omega t}$ and mass 2 as $X_2e^{i\omega t}$. Thus the equations of motion yield,

$$-m_1\omega^2 X_1 = -k_1 X_1 + k_2(X_2 - X_1) - i\omega c_1 X_1 + i\omega c_2(X_2 - X_1) + F$$

$$-m_2\omega^2 X_2 = -k_2(X_2 - X_1) - i\omega c_2(X_2 - X_1)$$

eliminating X_2 from these equations gives,

$$\frac{X_1}{F} = \frac{k_2 - m_2\omega^2 + i\omega c_2}{\left[k_1 + k_2 - m_1\omega^2 + i\omega c_1 + i\omega c_2 \right] \left[k_2 - m_2\omega^2 + i\omega c_2 \right] - \left[k_2 + i\omega c_2 \right]^2}$$

The response has an amplitude and phase and using a computer program these may be obtained. An example is shown in figure 2.14.

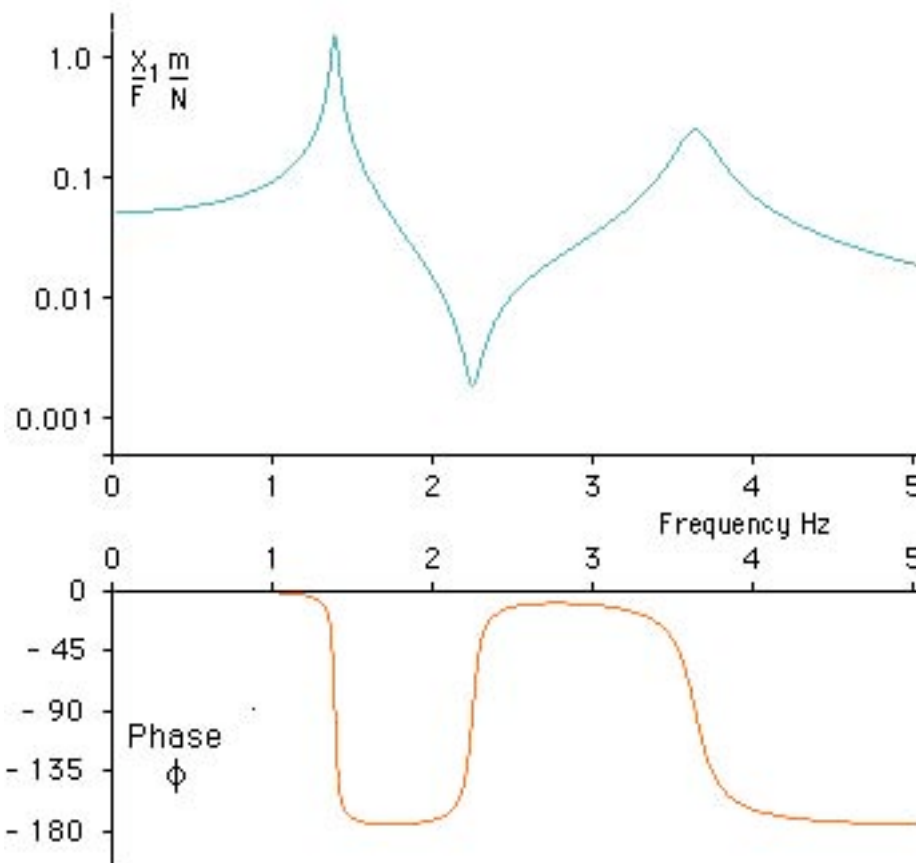

Figure 2.14 Amplitude and phase of forced response.



If the graphing program is used it will be found that two resonant peaks occur unless the damping is very high. There is usually approximately a 180 degree phase change across a resonance.

2.6 Vibration absorbers and detuners

The steady state responses shown in figures 2.13 and 2.14 have two interesting features. There are two resonant peaks of different magnitudes and there is a minimum response between the two resonances. It is possible to make the two resonant peaks equal in magnitude by reducing one while increasing the other. This is an optimum response situation. This will be considered later. First consider the minimum response for abutment excitation shown in figure 2.13. It is possible to make this zero. Equation (2.23) gave the steady state response for abutment vibration of the system shown in figure 2.7. ie, with no damping

$$\frac{X_1}{X_0} = \frac{(k - m\omega^2)k}{m^2\omega^4 + 3km\omega^2 + k^2} \dots\dots\dots (2.23)$$

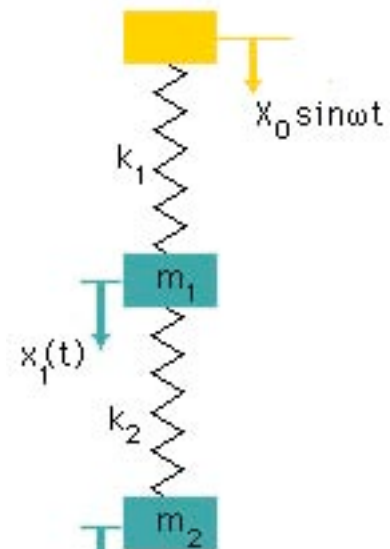

Figure 2.7 (as before)

It is evident from equation (2.23) that X_1/X_0 is zero when,

$$(k - m\omega^2) = 0 \text{ ie when } \omega = \sqrt{\frac{k}{m}}$$

At this frequency the abutment is oscillating but the mass 1 is stationary. Physically this is explained by the fact that the mass 2 is vibrating. The mass 1 then has equal and opposite forces applied by the springs on either side. How can the mass 2 be vibrating if the mass 1 is stationary and there is no excitation on mass 2? This is the same situation as for the one degree-of-freedom case. The second mass is vibrating at the natural frequency it would have if the mass 1 was an abutment ie $\omega = \omega_n = \sqrt{\frac{k}{m}}$. To produce an equal and opposite force on mass 1 the mass 2 will be vibrating anti-phase with the motion of the abutment. In some countries the mass 2 and the attached spring is called a detuner, in other countries it is called an undamped vibration absorber. Consider the detuner alone.

It has been shown that for steady state vibration,

$$\frac{X}{X_0} = \frac{k}{(k - m\omega^2)}$$

With no damping the force amplitude (F) on the abutment because of the motion is given by, $F = k(X_0 - X)$

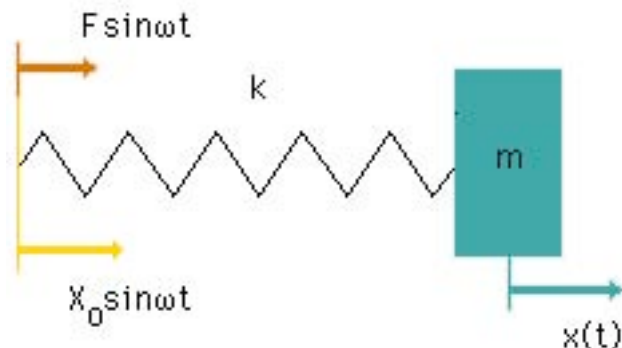

The 'Dynamic' stiffness at the abutment is given by the force amplitude (F) divided by the displacement amplitude X_0 ,

$$\frac{F}{X_0} = k \left(1 - \frac{X}{X_0} \right) = k \left(1 - \frac{k}{(k - m\omega^2)} \right) = k \left(\frac{(k - m\omega^2) - k}{(k - m\omega^2)} \right) = \frac{-km\omega^2}{(k - m\omega^2)}$$

It is apparent that the dynamic stiffness is infinite when, $(k - m\omega^2) = 0$.

which is when the excitation frequency $\omega = \sqrt{\frac{k}{m}}$.

Such a detuner will stop the vibration on any structure at the point where it is added. This also applies when there is damping in the structure to which it is added. However the detuner always has no damping.

The steady state response of the system shown may be shown to be,

$$\frac{X_1}{X_0} = \frac{(k_1 + i\omega c_1)(k_2 - m_2\omega^2)}{(k_1 + k_2 - m_1\omega^2 + i\omega c_1)(k_2 - m_2\omega^2) - k_2^2}$$

The response is zero when $(k_2 - m_2\omega^2) = 0$

this is when $\omega = \sqrt{\frac{k_2}{m_2}}$ and this is the natural frequency of the detuner alone and the frequency when it will exhibit infinite "dynamic" stiffness.

The response is shown in figure 2.15 for a particular set of values.

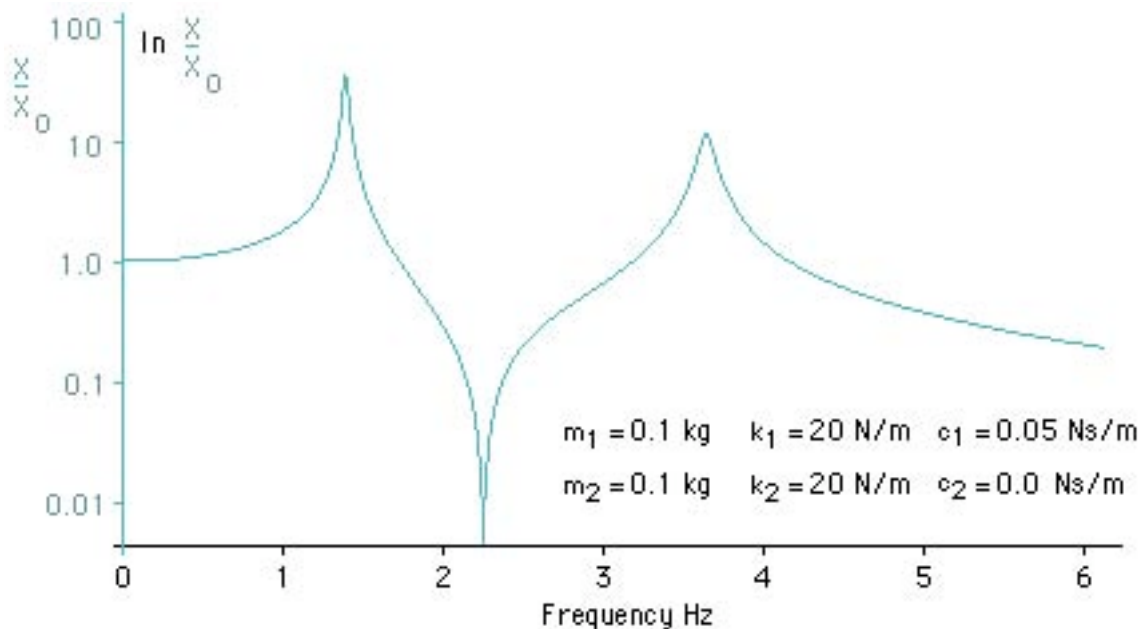
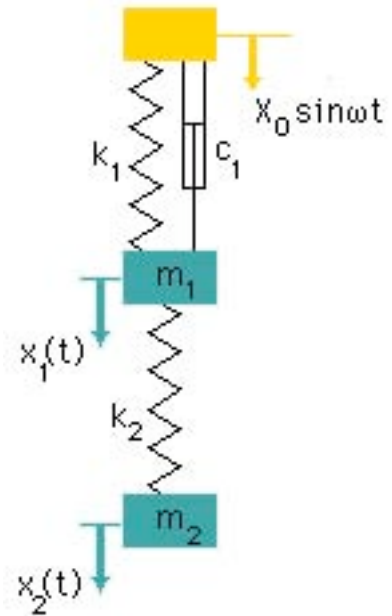

Figure 2.15 Response with a detuner added; abutment excitation.



It is important to remember that there will be start up transients with detuners and these may be significant.



A similar result is obtained with a detuner when an exciting force is applied to the mass 1 The response is shown in figure 2.16.



Again it is important to remember that there will be start up transients with detuners and these may be significant.

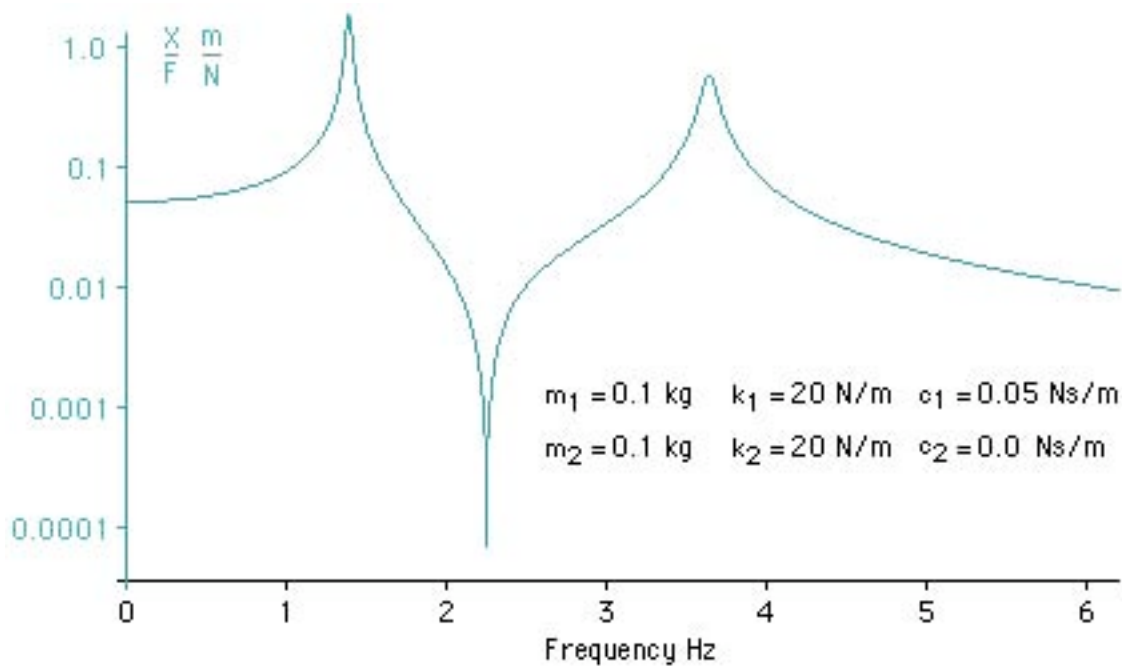
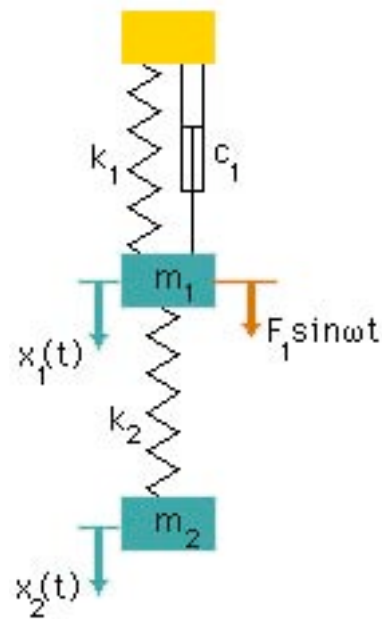

Figure 2.16 Response with a detuner added; force excitation.

The excitation does not effect the performance of the detuner unless the excitation is a force on the detuner mass. Thus an excitation of the mass 1 by an out-of-balance mass would also have zero response at the detuned frequency.

The detuner is only effective at a single frequency and in many practical situations the frequency of the excitation may not be constant. Under these circumstances a damped vibration absorber

(damped detuner) may be used with great effect. The damping means the "dynamic stiffness is not zero at any frequency but is high over a reasonable frequency range.

When optimising the response of an existing system by adding an absorber it is conventional to minimise the maximum response. This involves choosing values for the absorber mass, stiffness and damping. It is found that the larger the absorber mass the smaller the maximum response that may be achieved. Before computers, optimum values were found for the case with $c_1 = 0$. For this case the optimum values are given by

$$\frac{k_2}{k_1} = \frac{m_2 / m_1}{[1 + m_2 / m_1]^2} \text{ and } \xi_2 = \frac{2c_2}{\sqrt{m_2 k_2}} = \sqrt{\frac{3m_2 / m_1}{8[1 + m_2 / m_1]^3}}$$

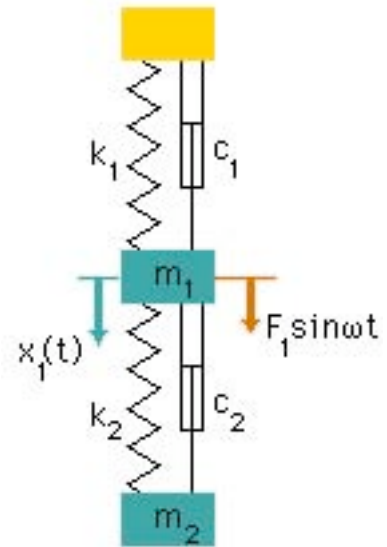

Figure 2.17

With the advent of computers, it is possible to find the optimum values for the general case including damping in the main system. For the system shown in figure 2.17 the optimum response is shown in figure 2.18.

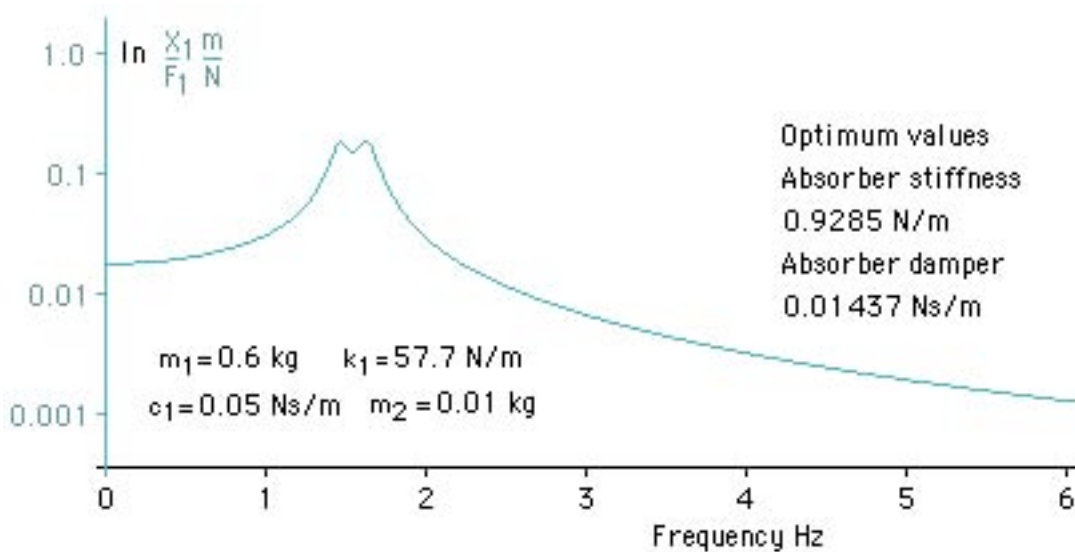

Figure 2.18 Response with optimised absorber.



Conclusions

It has been shown that a two degree of freedom system has two natural frequencies and associated mode shapes. For undamped systems it was further shown that the motion of a two degree of freedom system may be considered as the superposition of the motion of two one

degree of freedom systems. This applies to both transient and forced vibration. In the chapters that follow this will be found to apply to more complex systems. These may be considered to behave as the superposition of several modes of vibration each of which behaves in a similar manner to a single degree of freedom system.

The effects of damping have been shown to damp transients and reduce the amplitudes of vibration at resonance.

Also it has been shown how vibration may be reduced by the use of detuners and vibration absorbers. Detuners exhibit infinite stiffness at one frequency and are thus used for problems where there is a fixed frequency of excitation. Vibration absorbers are used when the maximum response needs to be reduced.
