

Summary of Useful Techniques Demonstrated in Iron Simulator Programs

Call SubVI by Reference

This allows the subVI to be selected when the program runs, rather than being fixed beforehand. The only restriction is the VI connector must be decided beforehand.

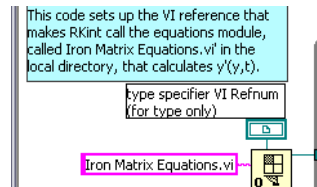

This part of the top level simulation module creates the subVi reference value (a blue-green line) for the equations module that will be called by the Runge Kutta integrator module.

The terminal 'type specifier Vi Refnum' is created by right clicking the appropriate terminal of 'Open VI Reference' and selecting 'Create->control'. Then we right click the terminal and select 'Select VI Server Class' and then browse for the subVI we want to call.

In this example, the connector pattern has already been defined when I built the module 'RkInt4.vi' (Runge Kutta 4th Order Integrator). That is why any new equations module must be built from the example supplied. Otherwise there will be a connector mismatch that will make the VI reference value invalid. This will give a broken wire instead of the reference.

A similar arrangement is used to call the control VI from the real time simulator. At the top level we have the following code fragment:

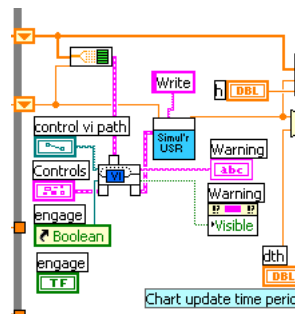

Here we supply the real time control subVI path with the state and controls clusters to the module 'VI Loader.vi'. This, in turn, calls the real time control subVI but only when the 'ENGAGE' button is pressed. It was quite tricky to set this up to meet the following requirements:

- Control subVI front panel displayed and moved to front (even if previously closed) when ENGAGE pressed.
- Warning message displayed if VI path is invalid.
- Control subVI panel can be minimized while running. Also main top-level VI window can be moved back to front by clicking on it to see the chart display.
- When ENGAGE pressed again to 'disengage' the control subVI, the control subVI can be edited and then re-engaged.

To do this, I had to set the control subVI window properties carefully. That is why the 'Sample Controller.vi' is supplied as a template. The Window Appearance properties are:

Title bar, Show menu bar selected

Allow user to Close Window Allow Runtime Popup Menu selected

Show front panel when loaded selected

In addition, several code features were needed in 'VI Loader'.

We pass a reference to the 'ENGAGE' button to 'VI Loader'. The 'ENGAGE' button has to have its mechanical action changed from the button default to 'Switch When Released'. The use of a reference enables 'VI Loader' to change the appearance of the button from within the subVI. If the control subVI cannot be loaded or run, then we reset the button to the 'off' (disengaged) state.

'VI Loader' also makes the control subVI panel visible when it is first run, ie when changing from the 'disengaged' state to the 'engaged' state.

Finally 'VI Loader' generates appropriate warning messages when its operations have not been successful.

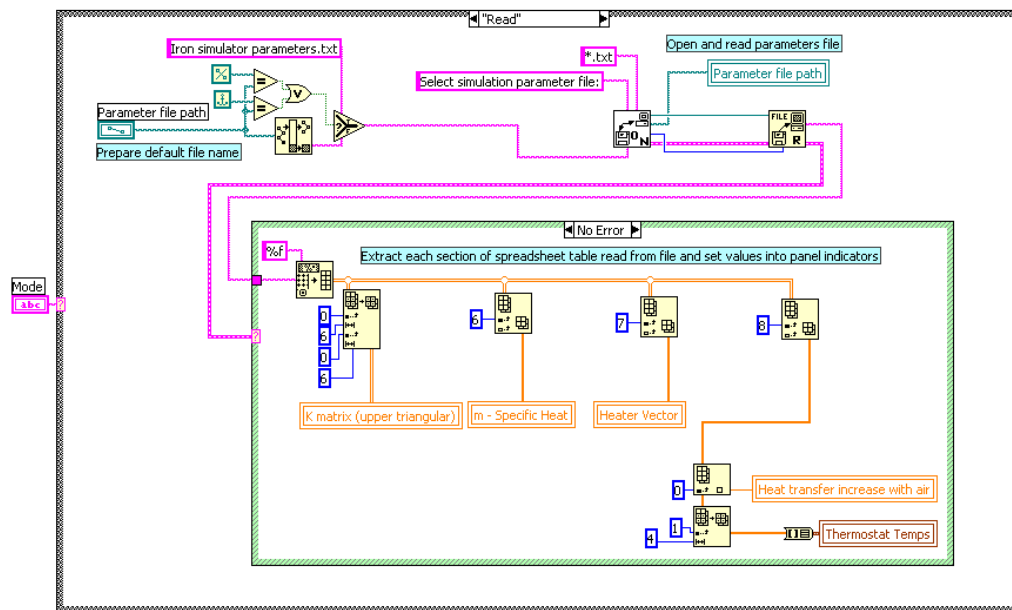

Save or Retrieve Default Parameter Settings

The 'K-Generator2.vi' module provides parameters for the simulation model. It is convenient to be able to save these parameter values to disc, and read them from a file at the start of a subsequent session.

This code shows the 'Read', 'Write' and 'Calculate' panels that form this module. The first two retrieve and save the parameter values using a spreadsheet file. Notice how the default file name is created in each case to make operation as convenient as possible.

